

QL Compact Thruster Series CT600/900

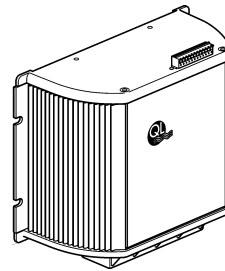
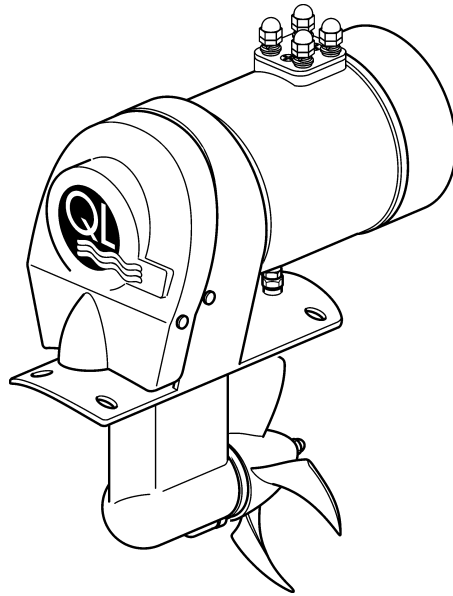

(ENG) **QL Compact Thrusters Series
CT600/900**
Installation Instructions

(ITA) **QL Compact Thrusters Series
CT600/900**
Installation Instructions

(GER) **QL Compact Thrusters Series
CT600/900**
Installation Instructions

(SWE) **QL Compact Thrusters Series
CT600/900**
Installation Instructions

(FRE) **QL Compact Thrusters Series
CT600/900**
Installation Instructions

(FIN) **QL Compact Thrusters Series
CT600/900**
Installation Instructions

(SPA) **QL Compact Thrusters Series
CT600/900**
Installation Instructions

Advanced copy



Marine Accessories
By Volvo Penta

IMPORTANT!

This batch with its accompanying instructions is produced for Volvo Penta's service workshops, boat-builders, machine manufacturers and other authorized workshops which have personnel with qualified professional training.

The installation instructions are only produced for professional use and are not intended for non-professional use. Volvo Penta will not assume any liability whatsoever for damage incurred, either damage to materials or personal injury, which may result if the installation instructions are not followed or if the work is carried out by non-professional personnel.

WICHTIG!

Dieser Satz mit vorliegender Einbauanleitung ist für Volvo Penta Kundendienst-werkstätten, Werften, Maschinenbauer und für andere ermächtigte Werkstätten mit beruflich geschultem Personal vorgesehen.

Die Einbauanleitung ist nur für den berufsmäßigen Gebrauch vorgesehen und nicht für unprofessionelle Anwendung gedacht. Volvo Penta übernimmt nicht die geringste Haftung für irgendwelchen Schäden an Personen oder Sachen, die als Folge einer Nichtbefolgung der Einbauanleitung oder wegen Ausführung der darin beschriebenen Arbeiten durch nicht beruflich geschulte Personen entstehen.

IMPORTANT!

Ce kit, avec instructions de montage, est destiné aux ateliers de service Volvo Penta, aux constructeurs de bateaux et autres ateliers de construction agréés avec un personnel qualifié.

Les instructions de montage sont exclusivement conçues pour une utilisation professionnelle. Volvo Penta se dégage de toute responsabilité pour d'éventuels dommages, corporels ou matériels, résultant du non respect des instructions ou d'un travail effectué par un personnel non compétent.

IMPORTANTE!

El presente juego con las instrucciones de montaje se destina a los talleres de servicio Volvo Penta, constructores de embarcaciones y máquinas y a otros talleres autorizados que cuentan con personal capacitado.

Las instrucciones de montaje están destinadas únicamente para uso profesional, por lo que Volvo Penta no aceptará responsabilidad alguna por cualquier daño, tanto personal como material, resultado de no haber seguido las instrucciones de montaje o de haber sido efectuado el trabajo por personal que no está debidamente capacitado.

IMPORTANTE!

Questo kit e le relative istruzioni di montaggio sono stati realizzati per le officine di servizio Volvo Penta, i cantieri, i fabbricanti di macchine e tutte le altre officine autorizzate il cui personale ha ricevuto un addestramento qualificato e specializzato.

Le istruzioni di montaggio sono state redatte esclusivamente per uso professionale e non sono adatte all'uso non professionale. La Volvo Penta non si assume alcuna responsabilità per eventuali danni alle cose o alle persone, derivanti da trascuratezza nel seguire le istruzioni di montaggio oppure dall'esecuzione dei lavori da parte di personale non qualificato.

VIKTIGT!

Denna sats med föreliggande monteringsanvisning är framtagen för Volvo Pentas serviceverkstäder, båtbyggare, maskintillverkare och övriga auktoriserade verkstäder som har personal med kvalificerad fackutbildning.

Monteringsanvisningen är enbart framtagen för yrkesbruk och är inte avsedd för icke yrkesmässig användning. Volvo Penta påtager sig inget som helst ansvar för eventuella skador, såväl materiella som personskador, som kan bli följden om monteringsanvisningen ej följs, eller om arbetet utförs av icke yrkeskunnig personal.

VIGTIGT!

Dette sæt med tilhørende monteringsvejledning er blevet udviklet for Volvo Pentas serviceværksteder, bådbyggere, maskinproducenter og andre autoriserede værksteder, som har medarbejdere med kvalificeret, faglig uddannelse.

Monteringsvejledningen er udelukkende beregnet til professionel anvendelse og ikke til hobby- eller fritidsbrug. Volvo Penta påtager sig intet som helst ansvar for eventuelle skader på såvel materiel som personer, som kan være en følge af at monterings-vejledningens anvisninger ikke blev overholdt, eller hvis arbejdet blev udført af ikke-professionelt personale.

TÄRKEÄÄ!

Tämä sarja ja asennusohje on tarkoitettu Volvo Pentan huolto-korjaamoille, veneenrakentajille, konevalmistajille ja muille valtuutetuille korjaamoille, joiden henkilökunta on saanut pätevän ammattikoulutuksen.

Asennusohje on tarkoitettu ainoastaan ammattikäyttöön. Volvo Penta ei vastaa mahdollisista materiaali- tai henkilövahingoista, joita asennusohjeen laiminlyöminen tai ammattitaidottoman henkilökunnan suorittama asennustyö voi aiheuttaa.

BELANGRIJK!

Deze set met de bijgevoegde montage-aanwijzing is ontwikkeld voor de werkplaatsen van Volvo Penta, botenbouwers, machinefabrikanten en overige bevoegde werkplaatsen, die personeel hebben met een gekwalificeerde vakopleiding.

De montage-aanwijzing is alleen ontwikkeld voor professioneel gebruik en is niet bedoeld voor niet-professioneel gebruik. Volvo Penta neemt geen enkele verantwoordelijkheid op zich voor eventuele schade, zowel materiële schade als persoonlijk letsel, die het gevolg kan zijn als de montage-aanwijzing niet wordt gevolgd, of als het werk wordt uitgevoerd door niet-vak-kundig personeel.

IMPORTANTE!

Este jogo, juntamente com as respectivas instruções de montagem, foi concebido para as oficinas de serviço da Volvo Penta, construtores navais, construtores de máquinas e outras oficinas autorizadas, com pessoal devidamente formado.

As instruções de montagem foram concebidas unicamente para utilização profissional e não se destinam a utilização não profissional. A Volvo Penta não se responsabiliza por quaisquer danos eventuais, tanto materiais como pessoais, que possam resultar no caso de as instruções de montagem não serem seguidas, ou se os trabalhos forem executados por pessoal não profissional.

Σημαντικό!

Η παρτίδα αυτή μαζί με τις οδηγίες που τη συνοδεύουν, παράγεται για τη συνεργασία της Volvo Penta, για κατασκευαστές σκαφών, κατασκευαστές μηχανημάτων και άλλα εξουσιοδοτημένα συνεργεία τα οποία απασχολούν εξειδικευμένο, κατάλληλα εκπαιδευμένο προσωπικό.

Οι οδηγίες εγκατάστασης παράγονται μόνο για επαγγελματική χρήση και δεν προορίζονται για χρήση από ερασιτέχνες. Η Volvo Penta δεν αναλαμβάνει καμία ευθύνη για ζημιές, είτε σε υλικά είτε σε άτομα, η οποία μπορεί να συμβεί εάν δεν τηρηθούν οι οδηγίες εγκατάστασης, ή εάν οι εργασίες δεν γίνουν από επαγγελματίες.

QL Compact Thruster **CT600** containing:

Designation	Qty	Item in fig
Thruster unit	1	1
Control unit *	1	2
Propeller	1	3
Driving pin, 5x46 mm steel	1	4
Washer, 6 mm	1	5
Locking nut, 6 mm	1	6
Bolt, M8	4	7
Washer, 8 mm	4	8
Locking nut, 8 mm	4	9
Washer, 8 mm	1	10
Nut, 10 mm	1	11
Nut, 8 mm	1	12
Plastic cap nut	4	13
Installation instructions	1	-

QL Compact Thruster **CT900** containing:

Designation	Qty	Item in fig
Thruster unit	1	1
Control unit *	1	2
Propeller	1	3
Driving pin, 5x46 mm steel	1	4
Washer, 8 mm	1	5
Locking nut, 8 mm	1	6
Bolt, M8	4	7
Washer, 8 mm	4	8
Locking nut, 8 mm	4	9
Washer, 8 mm	1	10
Nut, 10 mm	1	11
Nut, 8 mm	1	12
Plastic cap nut	4	13
Installation instructions	1	-

* Order separately

 This symbol is used in the installation manual and on the product, to call your attention to the fact that this is safety information. Always read such information very carefully.

Safety texts in the installation manual have the following order of priority:

 **Warning!**
Warns for the risk of personal injury, major damage to product or property, or serious malfunctions if the instruction is ignored.

 **Important!**
Is used to call attention to things which could cause damage or malfunctions to product or property.

Note! Is used to call attention to important information, to facilitate work processes or operations.

 **Warning!**
The bow thruster must not be installed in areas where inflammable or explosive gases may become present.

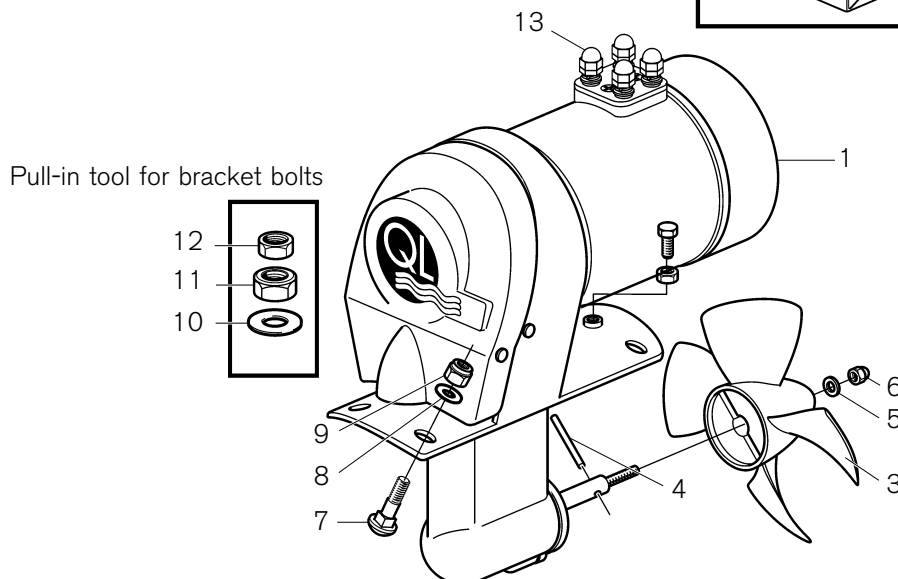
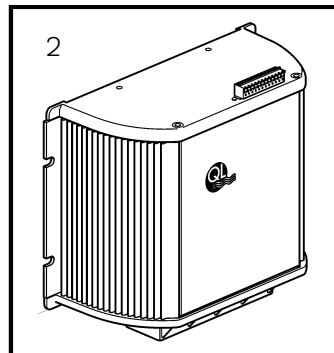

Thruster dimensions

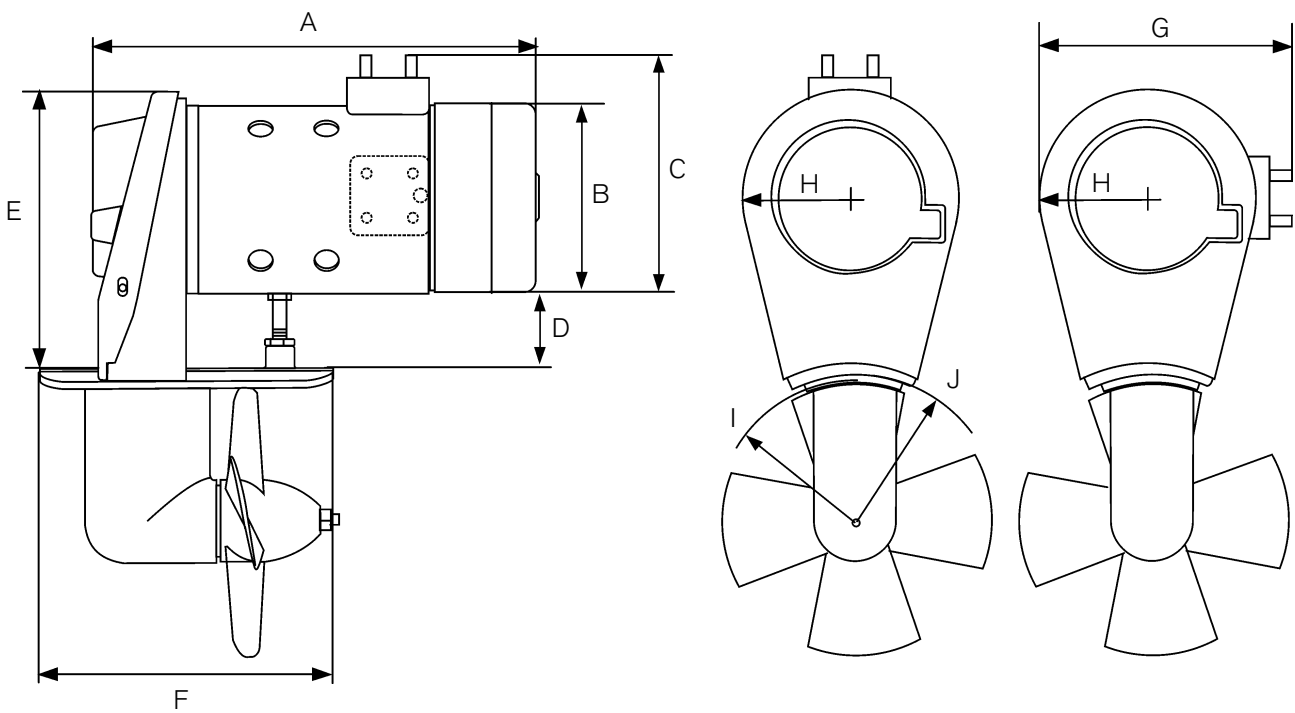

	CT600 - 12 V mm / inch	CT600 - 24 V mm / inch	CT900 mm / inch
A	316 / 12.44	255 / 10.04	310 / 12.2
B	129 / 5.08	129 / 5.08	130 / 5.11
C	175 / 6.89	175 / 6.89	175 / 6.89
D	15±8 / 0.6±0.32	15±8 / 0.6±0.32	50±8 / 1.97±0.32
E	150 / 5.91	150 / 5.91	190 / 7.48
F	192 / 7.56	192 / 7.56	200 / 7.87
G	185 / 7.28	185 / 7.28	190 / 7.48
H	65.5 / 2.58	65.5 / 2.58	75 / 2.95
I	80 / 3.15	80 / 3.15	92.5 / 3.74
J	85 / 3.35	85 / 3.35	97.5 / 3.84

Tunnel installation

Important!

Please read these instructions carefully and in their entirety before starting on the installation work.

The manufacturer does not assume any liability for the installation of the propeller tunnel and its attaining parts. Qualified installers should be familiar with these installation instructions. The responsibility for the installation rests entirely with the installer. Compliance with regulations must be ensured by the installer.

Use only an original QL-tunnel.

1. Choosing and marking the location

Select a suitable position for the bow thruster. For best results make sure that the bow thruster is located as far forward and as low in the hull as possible. To prevent air to be drawn into the tunnel, the tunnel's upper part should be minimum its diameter below the surface. See fig. 1

Use an appropriate drawing instrument, (refer to your dealer regarding availability of the drawing / cutting tools), to mark the point at which the hole for the bow thruster tunnel is to be inserted.

Tool P/N 41100791 (110 V) 41100792 (220 V)

Mark out the hole in its entirety on the inside of the hull so as to ascertain the optimum position for the tunnel. See fig. 2

Note! Make sure that the tunnel is mounted exactly transverse in the boat.

2. Cutting the holes

Drill one hole with a diameter of 25 mm (0.98") on each side of the hull as indicated by the compass points of the drawing instrument. Guide the tool gauge through the hull from the outside and cut out the large holes from both sides.

Note! It is important not to cut complete circles first. Small support lugs should be left on each side of the hull in order to support the tool gauge during the operation. A file can then be used to remove the support lugs once both holes are complete. See fig. 3

3. Determine the centre lines

Define a tunnel centre line (1) and the optimum propeller centre line (2). See fig. 4. The tunnel centre line is determined with reference to the tunnel and not to the boat.

See fig. 5 for suggestions how to find a centre line.

Note! The propeller can be mounted slightly offset from propeller centre line (2).

Fig. 1

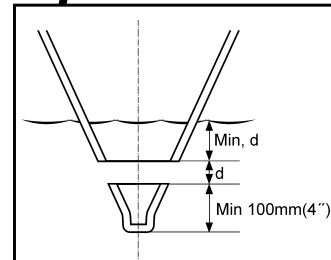
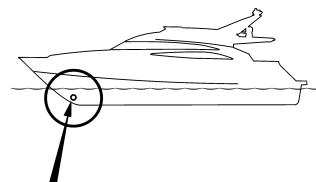

Fig. 2

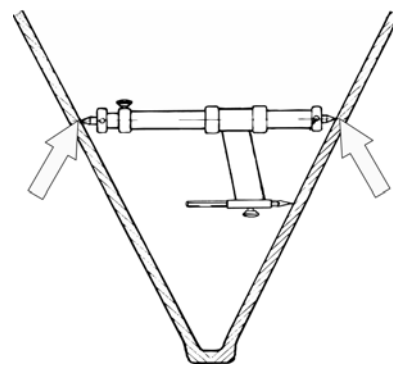

Fig. 3

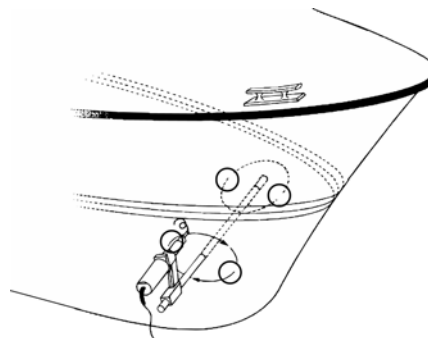

Fig. 4

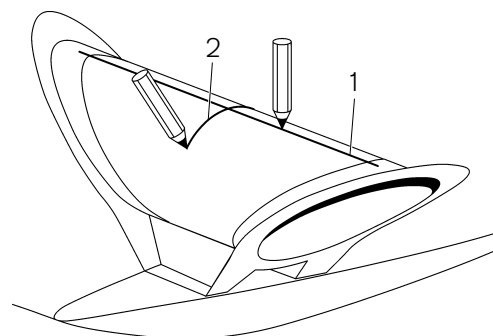
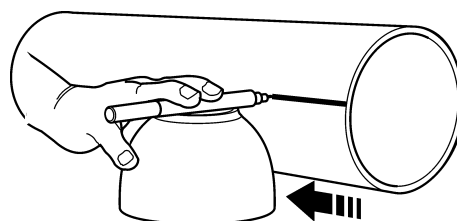

Fig. 5



4. Tilt of thruster

The bow thruster can be mounted in any angle, from 0° - 90°. Installation from 45° to horizontal requires a support for the motor. See fig. 6

5. Installing the tunnel

Put the tunnel in place and mark the shape of the hull, using a pen or a pencil, on the tunnel. See fig. 7

Note! Please read paragraph nr. 9 "Directions for special installations".

Cut the tunnel ends to desired shape and sand its surface and clean with degreaser where you are going to apply fibreglass. Soften the edges for better thrust. Best thrust is achieved when the finished openings are rounded with a radius equal to 10 % of the tunnel diameter. See fig. 7

6. Fastening the tunnel

Remove all topcoat from a surface area of at least 100 mm (3.94") around the holes on the inside of the hull (e.g. use a circular sanding disc) to get adhesion for the fibreglass. Vacuum clean and wipe down with degreaser.

Bond the tunnel to both sides of the hull. On the inside the bonding must cover 100 mm (3.94"). It is recommended that you use 7 layers of 450 g fibreglass mat for this purpose. See fig. 8

Note! There should be no fibreglass / polyester where the bracket is to be mounted.

Note! If the boat has a "sandwich hull" the core around the tunnel must be ground away sufficiently to allow the application of the fibreglass mat.

If there should be insufficient room for bonding around the tunnel, this space should instead be completely filled with polyester based filler.

7. Filler

Smooth out all the contact points/edges on the hull exterior with fibreglass filler.

Note! Best thrust is achieved when the finished openings are rounded with a radius equal to 10 % of the tunnel diameter. This will lead to less cavitation which is equal to solid thrust and less noise. See fig. 7

8. Coating

Prime the hull exterior with topcoat and two-component primer. Paint the hull and the tunnel exterior with antifouling paint.

9. Directions for special installations

On some boats (planing) it can be necessary to make structural alterations to divert the flow of water in front of the tunnel. This is to prevent water slamming into the propeller. See fig. 9

A: Level with the hull.

B: The tunnel should protrude 25 mm (0.98") from the hull.

Fig. 6

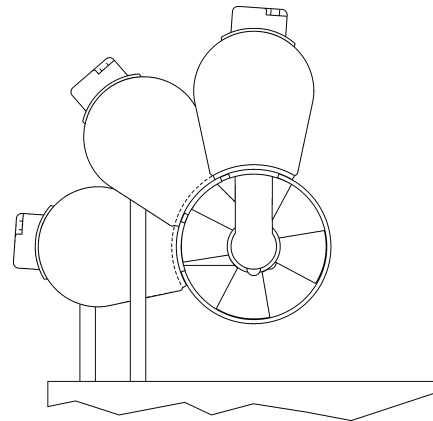

Fig. 7

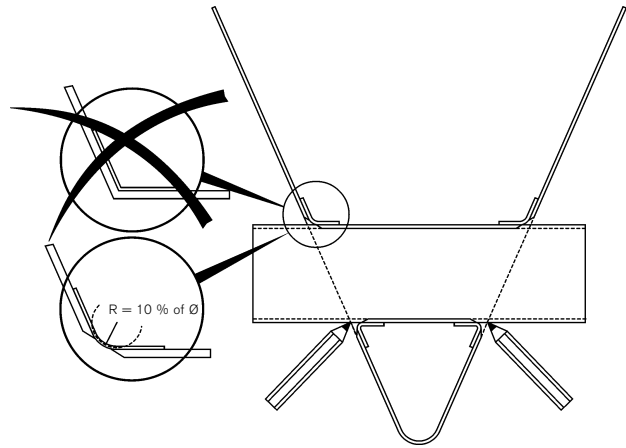

Fig. 8

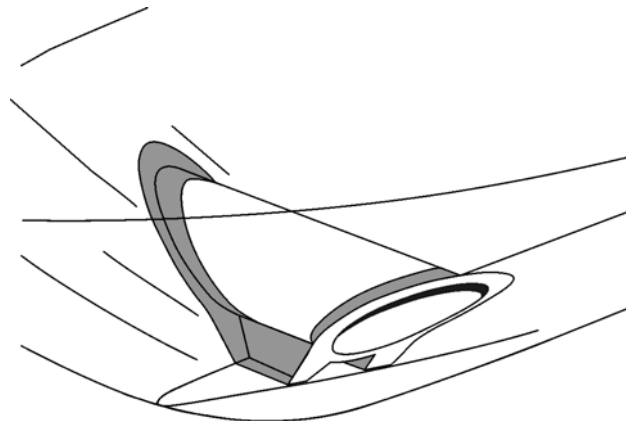
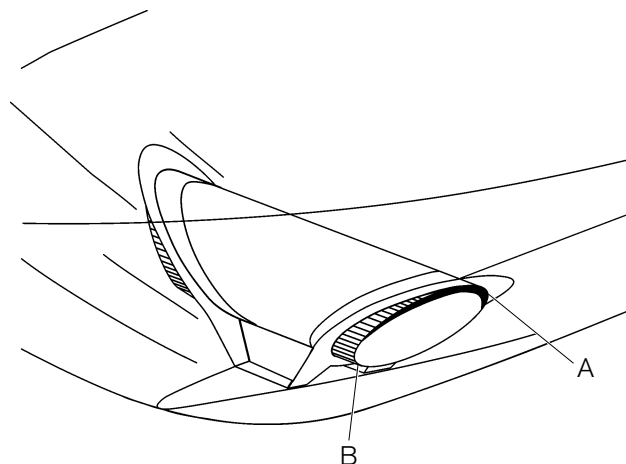

Fig. 9



7. Install CT600/900

Apply suitable sealant to the bracket and the bolts. Install the bracket and turn the propeller into place. Fasten the bracket with the washers and lock nuts. Fasten the washers and lock nuts with even turns in succession making sure that the propeller can rotate freely all the time. If needed, adjust the height by adding extra sealant. Smooth out the sealant in order to make even surfaces in the tunnel. See fig. 13 and fig. 15

Note! Do not install the driving pin, washer and locking nut as yet.

8. Minimum space

If the poles does not fit in their top placement position, undo the engine part from the consol and in optional direction, rotate $\frac{1}{4}$. See fig. 14

9. Installation of propeller

Install the propeller according to the propeller installation instructions (pub.no. 7745876).

Note! While fastening the lock nut a piece of wood could be used to prevent the propeller to rotate.

10. Paint

All wet parts in the tunnel must be covered with antifouling paint.

Note! Ensure that the installation has no leaks when the boat is set afloat.

Fig. 13

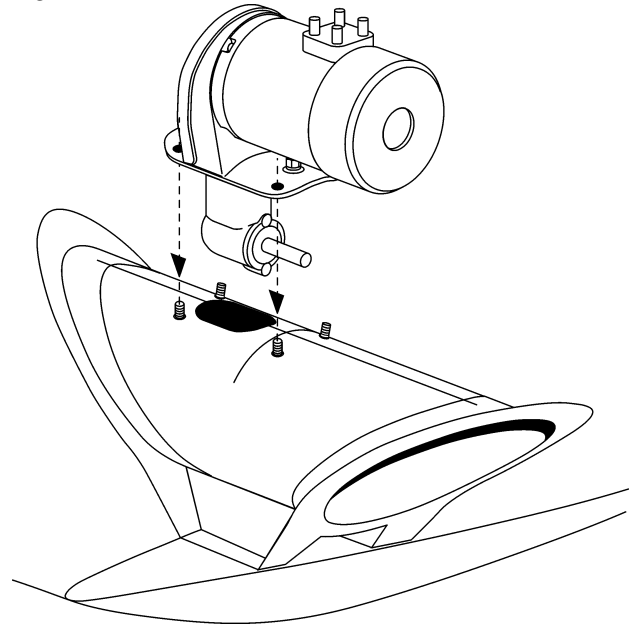

Fig. 14

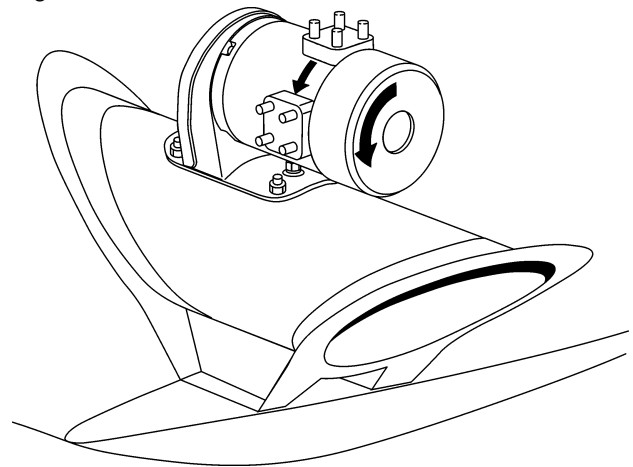
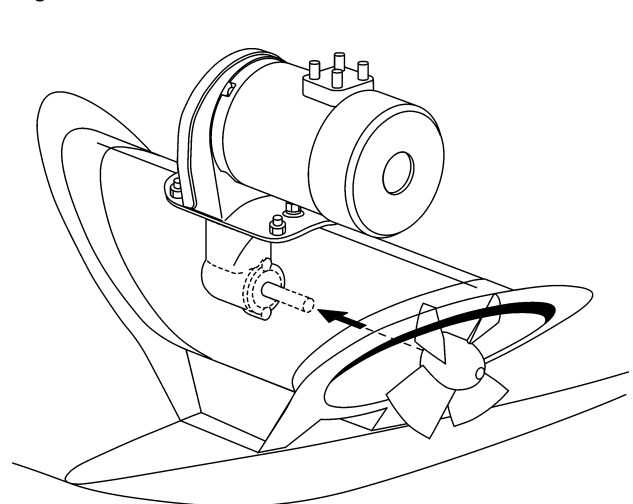

Fig. 15



Advice for the electrical installation

⚠ Important!

A qualified electrician must carry out the electrical work, and responsibility for the installation rests entirely with the installer.

⚠ Warning!

The electric power must be turned off during installation.

The minimum requirements stated below with reference to battery capacity, cable length and cable diameter must be adhered to, in order to avoid reduced performance and operational malfunction. Failure to adhere to these requirements will result in the loss of warranty coverage and may result in damage to the boat.

It is recommended to use of a dedicated battery bank for high ampere consumption equipment such as thrusters, windlasses, winches etc.

Recommended main switch, Volvo Penta P/N 1140319

⚠ Important!

To keep the resistance as low as possible. All connections between the power cable and components must be copper to copper, (or copper to brass). No washers of any kind shall be mounted between the power cable lug and the copper bar / component.

Fig. 16

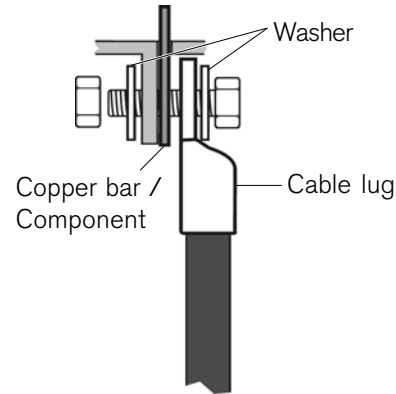

QL Thruster Cable requirements

Thruster	Motor	Recommended maximum cable length ¹⁾ -- minimum cable dimension.				Recommended minimum battery capacity		Recommended fuse amp.
		Length ¹⁾		Dim. ²⁾		Ah	CCA (SAE)	
		m	ft	mm ²	AWG			
CT600	12 V / 4 kW	1 - 10	1 - 33	95	3/0	100 Ah/12 V	800	350 A (P/N 41100819)
		10 - 20	33 - 67	120	4/0			
CT600	24 V / 4 kW	1 - 10	1 - 33	95	3/0	100 Ah/24 V	800	300 A (P/N 41100817)
		10 - 20	33 - 67	95	3/0			
CT900	12 V / 4 kW	1 - 10	1 - 33	95	3/0	150 Ah/12 V	1050	400 A (P/N 41100821)
		10 - 20	33 - 67	120	4/0			
CT900	24 V / 4 kW	1 - 10	1 - 33	95	3/0	150 Ah/24 V	1050	300 A (P/N 41100817)
		10 - 20	33 - 67	120	4/0			

1) The distance from the thruster unit to the battery, one way, each cable.
Use of even larger cable dimensions may improve thruster performance.

2) Wiring insulation rating is 105°C (221°F) minimum.

Connection diagram



Important!

The control unit must be the same voltage version as the battery and motor.

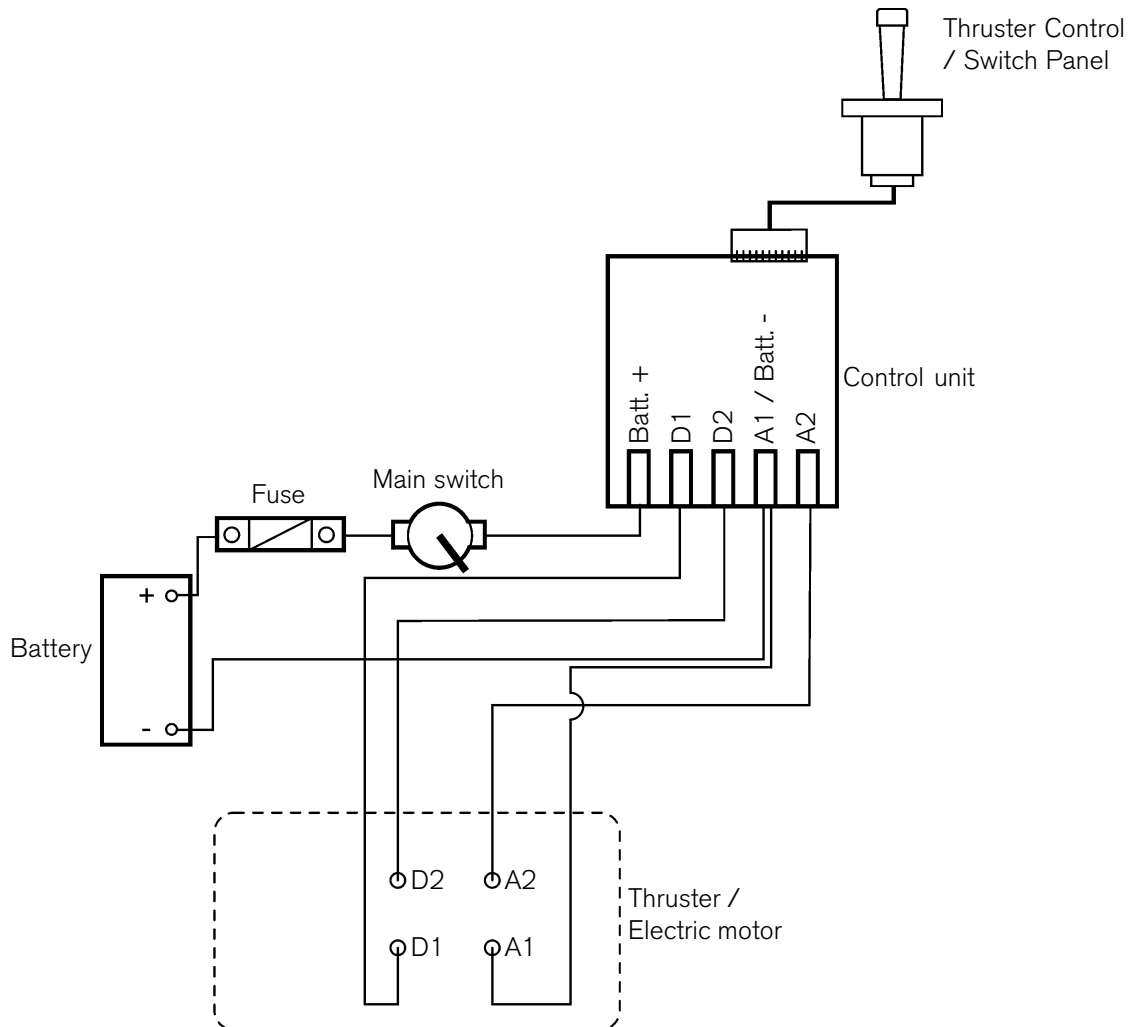

Note! All cables between the control unit and the electric motor shall have the same length. Maximum cable length is 1.5 m (5 ft). Minimum cable insulation rating is 105°C (221°F).

Minimum cable size is:

CT600 12/24V: 95 mm² (AWG 3/0)

CT900 12/24V: 95 mm² (AWG 3/0)

Electrical installation

1. Connecting the control cable

The wires are connected by pressing in the button placed over the hole while the wire is being pushed into the hole. Release the button when the wire is in place. See fig. 17

Note! The wiring must be connected as follows:

- Position 1: Green
- Position 2: Brown
- Position 3: White

Dual helm stations:

On boats with more than one steering/control position, the wires must be connected in parallel into 1, 2, and 3.

Fig. 17

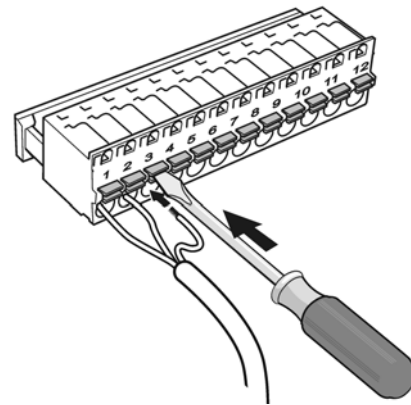

2. Connecting cables to the control unit

Connect the cables to the unit beginning from left to right (if it should be necessary to disconnect begin so from right). Note that all bolts are inserted from right, see fig. 18. Install the unit on the wall with the thick cables pointing downwards for more effective cooling of the control unit. Choose a well ventilated place where the unit is secure from moisture.

Fig. 18

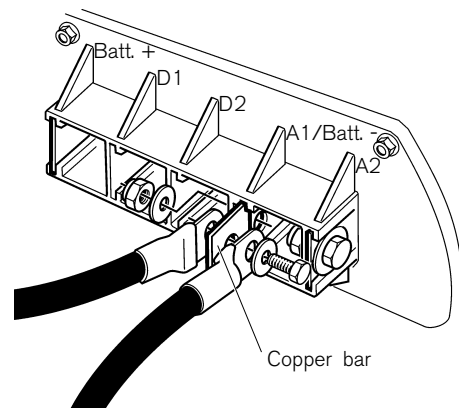

⚠ Important!

No washers of any kind shall be mounted between the power cable lugs and the copper bars. See fig 16

3. Connecting to the thruster

Connect the cables to the connection bolts as shown in fig. 19. Maximum cable length is 1.5 m (5 ft). Correct cable bolt nut torque is 10 Nm (7.4 lbf. ft).

- A1: Negative polarity (-)
- A2: Alternating polarity (+/-)
- D1: Alternating polarity (+/-)
- D2: Alternating polarity (+/-)

⚠ Warning!

After connecting the cables to the connection bolts with correct torque, the bolts and cables will still be able to move relative to the terminal plate. To make sure that no short circuits (contact) between the terminals can occur the cables should be secured and the connection bolts should be protected by plastic cap nuts and protective rubber caps.

Fig. 19

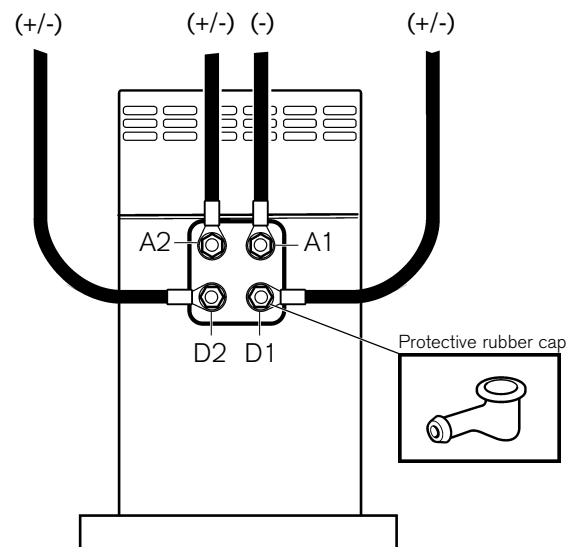

4. Connecting the cables to the battery

⚠ Warning!

Make sure that no cables are short circuited before connecting to the battery. Check all high current connections, tighten where necessary.

Connect the plus (+) and minus (-) cables to the correct poles on the battery and corresponding contacts on the control unit. The plus (+) cable must be connected via the fuse and main switch.

Test running



Warning!

Make sure no one is within reach of the rotating propeller and that no objects are in the tunnel before testing. Do not operate the thruster without the belt cover installed.

- Make sure that the battery is properly charged before testing.
- Avoid running the thruster out of the water. If necessary run only momentarily to verify operation.



Important!

Operation out of water or changing direction before the propeller stop rotating may cause damage to the main relay.

When the boat is launched:

- Turn the joystick to left/push left arrow button, and the boat moves to port. Turn joystick to right/push the right arrow button, and the boat moves to starboard. If not, switch the wires connected to no. 1 and no. 3 on the control unit (fig. 17).

Note! All power consuming equipment should always be run with care. The engine(s) or the onboard generator must always be running when the stern thruster is engaged to keep the generators charging the thruster batteries.

Installation checklist

Electrical

- Check that all electrical connections are tight and not corroded. Make sure that all connections are copper to copper.
- Check that cable dimension and length correspond to the QL Thruster requirements table.
- Check that fuse dimension correspond to the QL Thruster requirements table.
- Check the battery for clean and tight terminals. The battery capacity must correspond to the QL Thruster requirements table.
- Check the charging voltage measured on the battery. Correct charging voltage at 20°C (68 F) is:
 - 14.4 V on 12 V systems
 - 28.8 V on 24 V systemsCharge if necessary or replace battery/batteries
- For optimal thrust, voltage measured on the motor during operation should be more than:
 - 10.5 V on 12 V systems
 - 21.0 V on 24 V systemsIf the voltage is allowed to go below 10.5 V / 21 V, it will damage the relay.

Mechanical

- Check that all bolts are securely tightened and sealant is applied as instructed.
- Check that the propeller is fastened correctly to the shaft and can rotate freely in the tunnel.
- If the installation of the thruster is not upright within 0° to 45° vertical position, check that required motor support is installed.

General

- Correct drive direction as per control panel.
- Antifouling paint have been applied to all wet parts in the tunnel.