

isotherm
® by *indel marine*

Cruise Line **Marine Refrigerators**



INSTALLATION AND OPERATING INSTRUCTIONS

PRODUCED BY

GREAT WATER, INC.

BRUNSWICK MAINE

WWW.GREAT-WATER.COM

207 729 8500 TEL 517 813 6509 FAX

INFO@GREAT-WATER.COM

Table of Contents

- 1 Preface**
- 2 Installation**
 - 2.1 Unpacking and Inspection**
 - 2.2 Safety Considerations**
 - 2.3 Tools and Materials Required**
 - 2.4 Getting Good Results**
 - 2.5 Location and Ventilation**
 - 2.6 General Electrical Installation**
- 3 Boat's Electrical System**
- 4 Changing the Door Panel**
- 5 Re-hanging the Door**
- 6 General Maintenance**
 - 6.1 Defrosting**
 - 6.2 Cleaning**
 - 6.3 Storage**
- 7 Cruise Models with Traditional Thermostats**
 - 7.1 Electrical Connections**
 - 7.2 Operation**
 - 7.2.1 Start Up**
 - 7.2.2 Protection System**
- 8 Troubleshooting Guide for Cruise Refrigerators**
- 9 Cruise Models with ASU**
 - 9.1 Electrical Connections for Cruise ASU Models**
 - 9.2 Operation**
 - 9.2.1 Control Panel**
 - 9.2.2 Operation**
 - 9.2.3 INDICATOR LIGHTS**
- 10 Troubleshooting Guide for Cruise ASU Refrigerators**
- 11 Appendix I: How Refrigerators Work**

Isotherm Cruise Refrigerators

Installation and Service Manual

1 Preface

Isotherm Cruise refrigeration systems are designed and built to provide excellent performance and many years of trouble-free service. The system is pre-charged with environmentally safe R-134a refrigerant and can be owner-installed. This manual has been prepared to provide information needed for proper installation, operation and maintenance. Before starting please read it carefully.

2 Installation

2.1 Unpacking and Inspection

Please examine the box and contents for signs of shipping damage. If there is any damage, contact the carrier immediately. All units are shipped with insurance but the carrier must be notified immediately of any shipping damage in order to process a claim.

2.2 Safety Considerations

Whenever working on the electrical system make certain that all circuits are off before opening any electrical panels. Disconnect shore power cables and turn battery switches off. Follow **ABYC** standards for electrical installations. If in doubt contact a certified technician.

All Cruise refrigerators use environmentally safe R-134a refrigerant with "0" Ozone depletion potential. R-134 is non toxic; in the unlikely event that it is released from the sealed system it poses no hazard.

2.3 Tools and Materials Required

- Electric drill and bits for pilot holes to attach mounting frames.
- Wire cutters and electrical terminal crimping tool.
- Good quality electrical wire of suitable gauge (usually 10/2).
- Screwdrivers.

2.4 Getting Good Results

All Cruise refrigerators are designed for use in a marine environment and will operate efficiently for many years with a minimum of maintenance if installed properly. Plan the installation carefully and choose a suitable location for the refrigerator that will protect the components at the rear of the refrigerator (the tubing, condenser, and compressor) from exposure to seawater or from damage that could result from chafe or falling objects. Mount the refrigerator securely to prevent movement.

2.5 Location and Ventilation

All refrigerators are heat-transfer machines. They transfer the heat from the inside of the box to the outside. If adequate ventilation is provided, the compressor will operate more efficiently and use less power.

Inlet vent should be located at the bottom (as low as possible) and the outlet vent at the top of the refrigerator (as high as possible); this supports the natural flow of convection of heat from cool (bottom) to warm (top).

A vent of 20 to 30 square inches is recommended at top *and* bottom.

2.6 General Electrical Installation

Good performance and efficient operation of the refrigeration system depends on a good electrical installation that will deliver power to the system with a minimum of voltage loss. If the boat's electrical panel cannot deliver the required power with no more than a half volt of loss the circuit may need to be connected directly to the boat's main battery switch. In either case the circuit that supplies the power to the refrigerator must be protected with either a 15 amp fuse or circuit breaker. Always use a separate dedicated circuit to power the refrigeration system. Remember that the negative connection is equally important in delivering power to the unit.

Use a good quality marine duplex wire to make the connection between the unit and the power source. Tinned cable is recommended because it will give better resistance to corrosion and long service life.

Keep the length of the run as short as possible.

For runs up to 10 ft. use 12 gauge wire (12/2 duplex).

For runs up to 30 ft. use 10 gauge wire (10/2 duplex).

Make sure the circuit is not connected to the power source while making these connections.

3 Boat's Electrical System

A refrigeration system when properly installed and operating efficiently will still be a major consumer of electrical power. It is important to make sure that the boat's electrical system is in good order and is large enough to supply the power required. A good rule of thumb is reserve between 75 to 100 ampere hours of battery capacity in the main house battery bank for supplying the refrigerator. It is also a good practice to reserve a separate battery bank for starting the engine.

The connections to the battery switches and electrical panel need to be large enough to supply power with a minimum of voltage loss.

Battery Chargers - Most modern battery chargers have regulation circuits that will allow them to charge the boat's batteries continuously. This also means that they will be able to supply power to the refrigeration system when shore power is available. Make sure the battery charger has this feature. A charger with at least a 10 amp output is recommended. The charger must always be connected to the battery and never directly to the refrigerator's electronic unit. (Fig. 13).

Alternators - Most marine engines are equipped with an alternator that is mainly intended for charging the engine starting battery. In order to also charge the boat's house batteries quickly and efficiently it is good to increase the size of the charging leads. Installing a high output alternator with a separate regulator that will directly sense the voltage in the house batteries is a good way to improve the charging to the house bank.

4 Changing the Door Panel

To suit various boat interiors, the doors of all Cruise refrigerators are available as accessories with panels in white, black, mahogany, teak, and cherry. They may also be covered in other materials of choice.

1. To replace the panel, remove the strip on the lower edge of the door. (Fig. 1)
2. Remove the latch.
3. Slide the new panel into place over original panel.
4. Replace the latch and the plastic strip at the lower edge of the door.

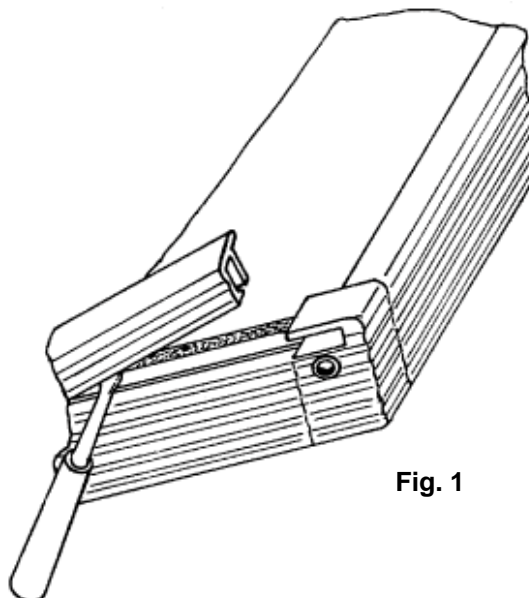

Fig. 1

5 Re-hanging the Door

All Cruise refrigerators doors are hung with the hinges on the right hand side of the box. To re-hang the door with the hinges on the left follow these steps (Fig. 2 & 3):

1. Make sure the door is empty.
2. Remove the bottom hinge bracket.
3. Remove the door.
4. Unscrew top hinge pin.
5. Screw top hinge pin on left hand side.
6. Unscrew the door latch and reattach on the right-hand side of the door.
7. Move the bottom hinge pin bracket to the left hand side of the refrigerator box and reattach.
8. Check the hanging of the door to make sure it is latching and closing properly.

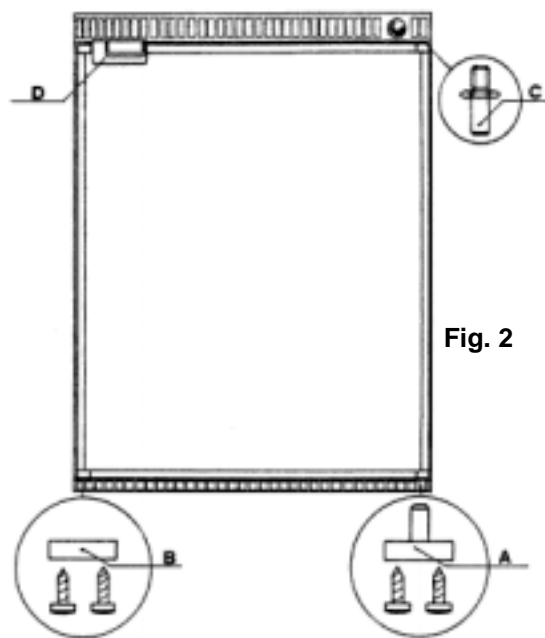

Fig. 2

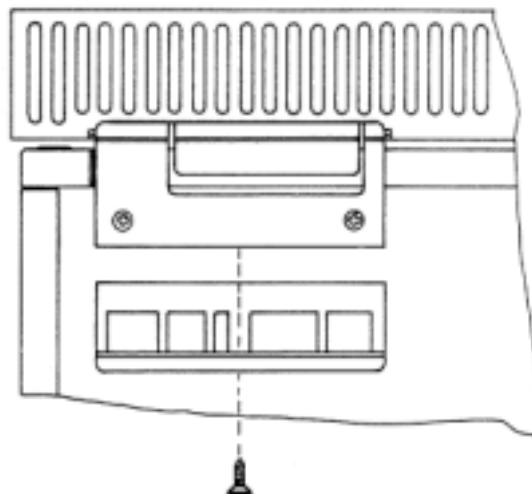

Fig. 3

6 General Maintenance

6.1 Defrosting

How often defrosting is needed depends on usage (how often door is opened) and humidity. Moist air will produce more frost on the evaporator. It is time to defrost when frost builds up to 1/4 inch.

The best way to defrost the refrigerator is to remove all food and place a towel inside the refrigerator, on the bottom of the box. Turn the thermostat to the "off" position and leave the door open.

Never use a knife to scrape ice from the evaporator. This will damage the evaporator and allow the refrigerant to escape.

6.2 Cleaning

The best time to clean the refrigerator is after defrosting. Wipe the inside clean using soap and water or a non-abrasive cleaner.

If you notice your refrigerator running longer than normal it may be time to clean the condenser (usually required every 1 to 2 years).

The condenser is located behind the refrigerator and can be cleaned by using a vacuum cleaner with a soft brush attachment to remove dust and dirt.

Take care not to damage the condenser or to remove the protective paint finish.

6.3 Storage

When the boat is laid up for storage it is best to defrost, clean and dry the interior of the refrigerator. The door can be set slightly open with the latch to provide ventilation to the interior. This will prevent mildew growth. (Fig. 4 & 5)

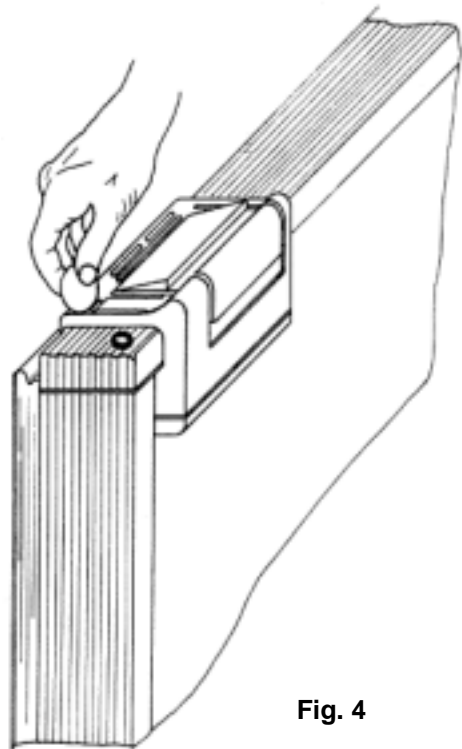

Fig. 4

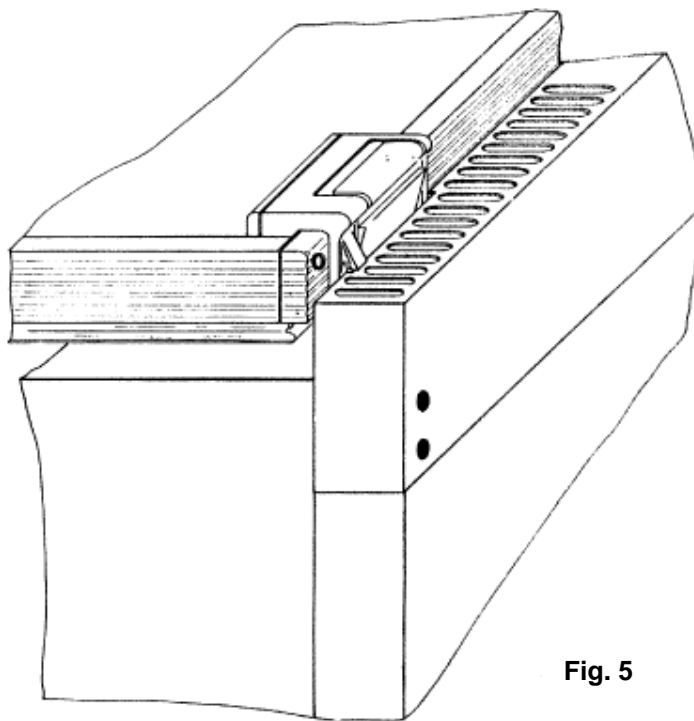
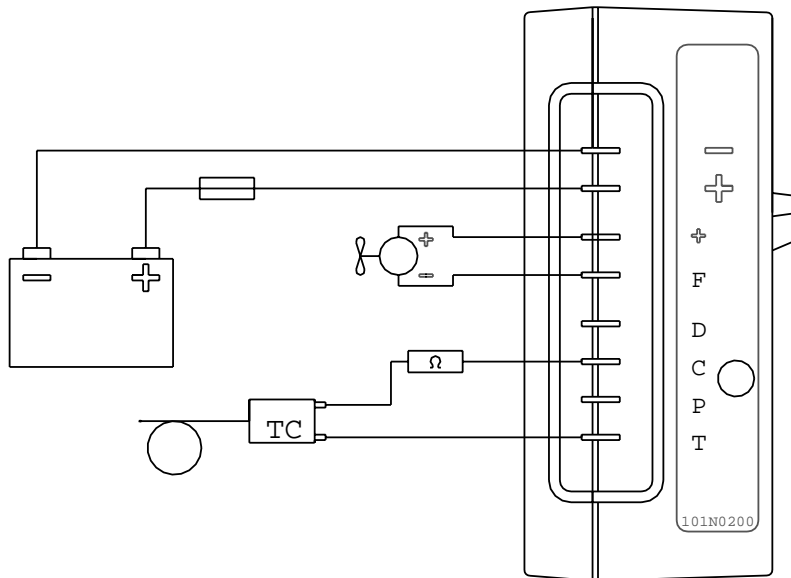

Fig. 5

7 Cruise Models with Traditional Thermostats

7.1 Electrical Connections



7.2 Operation

7.2.1 Start Up

Make sure the circuit supplying the refrigerator is turned on. The thermostat is adjustable and has an on/off switch. Turning the control knob to the extreme counter clockwise position turns the unit off. Turning the control to the right (clockwise) will turn the unit on. Turning the control clockwise lowers the temperature setting with the lowest temperature at the extreme clockwise position.

A good initial setting is mid-range.

7.2.2 Protection System

The compressor is equipped with an electronic protection system. The system is activated when the compressor is overloaded and fails to start for any reason. It is also activated if the batteries are under- or overcharged.

To prevent battery damage the protection system will shut off the compressor when the input voltage at the electronic module falls below 10.3 volts. The compressor will not start again until the input voltage rises to 11.5 volts.

8 Troubleshooting Guide for Cruise Refrigerators

Problem	Possible Cause	Action
Refrigerator isn't cold.	Compressor won't start.	Check that power is present at terminal box. Check fuse. Check all connections and cables. Check the thermostat. If the compressor still doesn't start this indicates a fault in the electronic unit or compressor. Contact an authorized service agent.
	Compressor starts but doesn't cool refrigerator.	Contact an authorized service agent.
Compressor runs all the time.	Air leak.	Check gasket/seal of door. Make sure door is closing properly.
	Condenser dirty.	Clean condenser using vacuum with soft brush attachment.
	Insufficient ventilation.	Improve ventilation. Refer to installation instructions.

9 Cruise Models with ASU

9.1 Electrical Connections for Cruise ASU Models

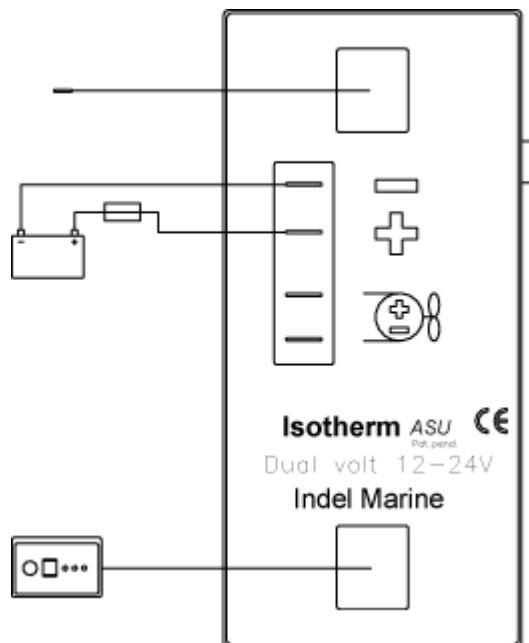

9.2 Operation

9.2.1 Control Panel (Fig. 6)

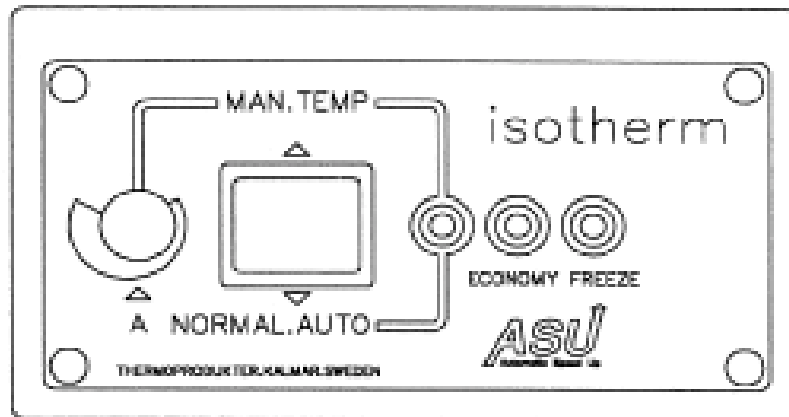

Fig. 6

The control panel is equipped with:

- A three position rocker switch.
- Green, yellow and red LED status indicators.
- Rotary control for temperature adjustment in the Manual mode.

The control panel connects to the **ASU** processor on the compressor using a 12 ft. telephone type cable with modular connectors at each end.

A 30 ft. long accessory cable is available if needed. (Part No. 39230).

The **ISOTHERM ASU** refrigeration system can be operated in two modes.

- In the “**NORMAL.AUTO**” position the **ASU** program manages the temperature and compressor operation. Optimum refrigeration temperatures are maintained and compressor operation is managed to consume a minimum of battery power.
- In the “**MAN.TEMP**” position. The temperature can be manually adjusted.

In the center position the unit is switched off.

9.2.2 Operation

“**NORMALAUTO**” position:

The green light indicates that power is on and the **ASU** program is running.

The **ASU** feature senses when surplus power is available—from the engine alternator, solar panels or wind chargers—and switches the compressor to high speed, quickly freezing the holding plate. Thermal energy stored in the holding plate will keep the refrigerator cool for many hours without consuming battery power. The **ASU** control then will restart the compressor at a low speed, using a minimum of power to maintain a stable temperature in the box.

The yellow “Economy” LED indicates low-speed compressor operation.

The red “Freeze” LED indicates high-speed compressor operation.

The **ASU** processor monitors the supply voltage. When the voltage rises above 13.2 (26.4) volts it will start the compressor and after a short delay gradually increase the speed of the compressor and cooling fan. The indicator LED will shift from yellow to red. This operating condition is maintained until the holding plate is completely frozen at approximately -14°C (7°F). This can take between 45 minutes and 2 hours depending on the model, ambient temperature and box size.

As long as the **ASU** processor senses surplus power the holding plate is maintained in the frozen condition. If the holding plate temperature rises to -10°C (14°F), the compressor re-starts and the red LED comes on again.

When the supply voltage falls below 12.7 (25.4) volt, the refrigeration energy stored in the holding plate will maintain the box temperature for many hours (up to 12 hours depending on the box size, ambient temperature and insulation).

When all the thermal energy stored in the holding plate is used and the plate temperature rises to -1°C (30°F) the ASU system will start the compressor at a low speed to bring the plate temperature down 6°C (21°F). This will maintain a very stable box temperature using the minimum amount of battery power.

“MAN.TEMP” position:

This position can be used when shore-power is connected and energy saving is not required or whenever a higher or lower refrigerator temperature is desired. The ASU program is stopped and the temperature is regulated by means of the temperature knob on the control panel. Turn the control clockwise for a colder temperature setting. The “A” (Accumulation) position approximates the freezing point of the holding plate.

In the “MAN.TEMP” position, the compressor runs at a low speed to maintain the set temperature. If the difference between the set and actual temperature is greater than 6°C, the compressor will automatically speed up for faster cooling. As soon as the temperature comes down the compressor speed will be reduced for the lowest power consumption and quietest operation.

9.2.3 INDICATOR LIGHTS

Green: Power and system on, compressor not running. Set temperature reached.

Green + Yellow: Compressor running at low speed in Normal Auto mode.

Green + Red: Compressor running at high speed in the Normal/Auto mode.

Green + Yellow + Red: Compressor running in MAN.TEMP mode.

Flashing Yellow and/or Red: Error signal. See Troubleshooting Guide.

Automatic Defrosting will take place automatically every tenth day of operation.

10 Troubleshooting Guide for Cruise ASU Refrigerators

Problem	Possible Cause	Action
Nothing happens when turned on. All lights off.	No power supply.	Check that main power switch is on. Check fuse.
Green light on. Compressor does not start.	Holding plate cold enough.	No action required.
	Temperature sensor not connected.	Check cable.
	Fault in control unit.	Replace.
Yellow light flashing. Low voltage cut-out activated.	Battery in poor condition.	Inspect charging circuit.
	Voltage drop due to thin cables.	Measure voltage drop when running and replace cables if needed. Switch off, wait 5 sec.
Red light flashing. Overload cut-out activated.	Oil compressor too thick at <41 C.	Frequent restarts as above. Warm compressor.
	Faulty fan.	Check fan.
Yellow/red lights flashing.	Shore-power driven charger that cannot compensate when compressor runs at high speed.	Switch to "MAN.TEMP" and choose suitable temperature on control panel.
Compressor runs, but no refrigeration generated.	Loss of cooling medium.	Contact specialist to fill cooling medium.
	Connections not tight enough.	Inspect and tighten.
Compressor runs often, but temperature in box isn't cold enough.	Poor insulation	Re-insulate
	Fan not running or too warm in compressor compartment.	Repair fan or ventilate the space using air hose kit (part #10-10013).
	Too much gas in system (frost on pipe)	Refrigeration specialist to check gas pressure and adjust quantity.
Compressor never stops running- & not sufficiently cold.	See above.	See above.
& too cold.	Temperature sensor faulty.	Renew.
& temperature can't be reduced manually.	Temperature sensor touching box wall or ice build-up.	Adjust sensor or defrost by switching off system.
Compressor keeps running when engine is stopped.	Batteries in excellent condition, or extra power source (solar panel, wind generator, etc.)	Normal operation. If temperature becomes too cold switch to "MAN.TEMP".
Compressor won't run at full speed & red light not on when engine is running.	Poor charging. Plus or minus cables too thin.	Check charging, cables, etc. and rectify.
	Connections affected by verdigris, loose fuse.	Clean & grease. (Correct voltage >13.4 V measured at control unit w/ compressor & engine running.)
Radio interference when running.	System is suppressed and fulfills present regulations.	Fit additional suppressor. Part# 10-39035 (20A Puresound).
Fuse blows.	Crossed +/- leads. Fault in control box.	Renew 20 (15) a fuse or control box.

11 Appendix I: How Refrigerators Work

How It Works

A refrigerator is a heat transfer system. A popular misconception is that “the thing” (the evaporator or holding plate) inside the box is radiating cold. It is more precise to say that the evaporator is absorbing heat from the contents of the box. By absorbing heat the products are cooled.

Refrigeration systems have three major components connected in a recycling circuit. (Fig. 1)

1. The evaporator is the heat collector located inside the box.
2. The compressor pumps a refrigerant gas around the system.
3. The condenser is a heat exchanger that transfers the collected heat to the air or water used to cool the system.

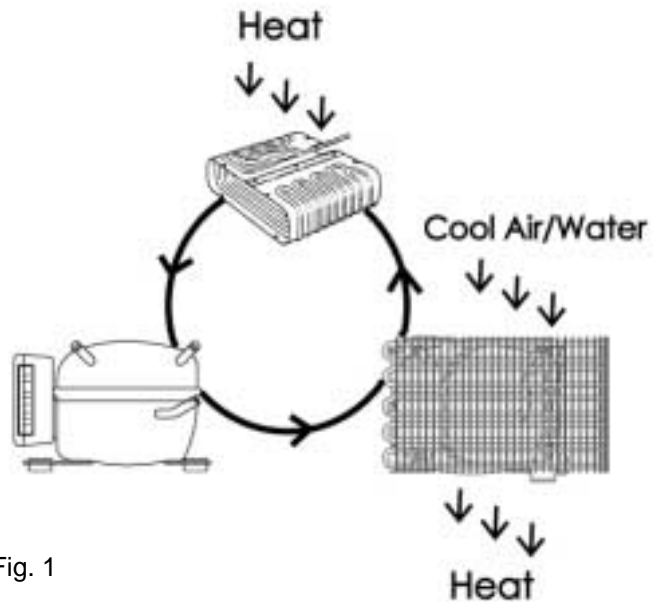

Fig. 1

The Refrigeration Cycle

.....Liquid refrigerant is carried into the evaporator where it boils into a gas. Just as it takes a lot of heat to boil water, a lot of heat is absorbed from the box to boil the refrigerant. The main difference is the refrigerant boils at a much lower temperature than water.

The boiled refrigerant gas is pumped out of the evaporator by the compressor allowing the boiling process to continue. The heat is carried out of the box by the gas. As the gas passes through the compressor, its pressure and temperature increase.

This compressed gas then passes to the condensing unit, a heat exchanger that is cooled with either air or water. Because the refrigerant is now at a higher pressure, it is possible to expel the heat from the system into the cooling air or water which is at the ambient temperature (60°F-90° F). This cooling process converts the high pressure gas to a cool liquid that is carried to the evaporator and the cycle begins....

The cooling medium used in Isotherm systems is R134A, an ozone-friendly refrigerant. This is commonly called “freon”. Freon was a brand name applied to an R12 product that has been phased out for environmental reasons.